

PRODUCT NAME		CONFECTIONERY SHOWCASE			
DESCRIPTION		CNZ-90 (Cold)			
CABINET	DIMENSIONS		W	D	H
		EXTERNAL	900	510	860
		INTERNAL			
EXTERIOR		Color Panel / Stainless			
INTERIOR		Glass			
SHELVE		Glass * 2 PLUS Base			
DOOR		Sliding Glass Door * 2			
REFRIGERATION CYCLE	COMPRESSOR	SC18G Danfoss			
	OUTPUT	7300 BTU			
	FREON	R134A			
	EVAPORATOR	FIN TUBE FORCED CIRCULATION			
	FAN	EVAPORATOR FAN : YZF10-20*1 CONDENSOR FAN : 5548152,20W*1			
	POWER	220-240V 50/60HZ			
	CONTROLLER	TL-550			
CONDENSOR		FIN TUBE FORCED AIR			
COOLING PERFORMANCE		INTERNAL TEMP : 3 ~ 6°C INTERNAL RH : 70~80%			
WEIGHT		150 Kgs			
PRICE FOB MANILA					

Exclusive Philippine Distributor:

STA. ANA IMPORT EXPORT INC.

3874 Macabulos St., Bangkal, Makati City, Philippines, 1233

Tel Nos. 889-0040, 889-0049, 889-0051, and 843-1322

Fax No. 889-0050

Email: Kinco@eastern.com.ph

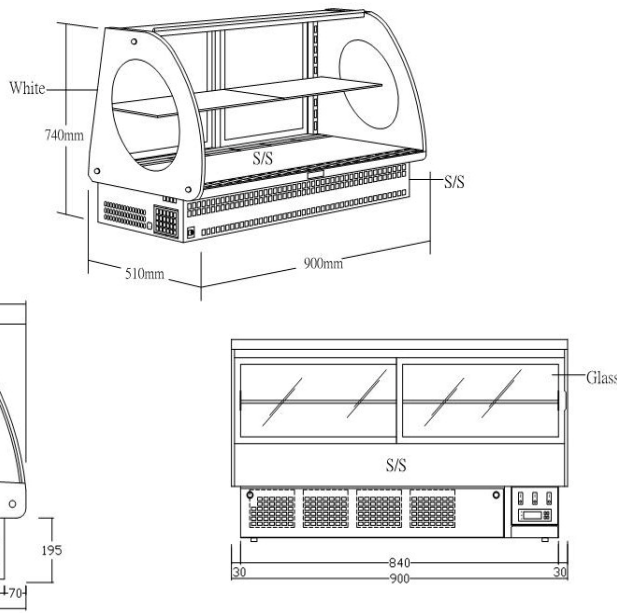

PRODUCT NAME		COUNTER TOP SHOWCASE			
DESCRIPTION		KTH-90 (Cold)			
CABINET	DIMENSIONS		W	D	H
		EXTERNAL	900	510	740
		INTERNAL			
EXTERIOR		Color Panel □			
INTERIOR		Glass			
SHELVE		Glass * 1 PLUS Base			
DOOR		Sliding Glass Door * 2			
REFRIGERATION CYCLE	COMPRESSOR	SC18G Danfoss			
	OUTPUT	7300 BTU			
	FREON	R134A			
	EVAPORATOR	FIN TUBE FORCED CIRCULATION			
	FAN	EVAPORATOR FAN : YZF10-20*1 CONDENSOR FAN : 5548152,20W*1			
	POWER	220-240V 50/60HZ			
	CONTROLLER	TL-550			
CONDENSOR		FIN TUBE FORCED AIR			
COOLING PERFORMANCE		INTERNAL TEMP : 3 ~ 6°C INTERNAL RH : 70~80%			
WEIGHT		120 Kgs			
PRICE FOB MANILA					

Exclusive Philippine Distributor:

STA. ANA IMPORT EXPORT INC.

3874 Macabulos St., Bangkal, Makati City, Philippines, 1233

Tel Nos. 889-0040, 889-0049, 889-0051, and 843-1322

Fax No. 889-0050

Email: Kinco@eastern.com.ph



	PRODUCT NAME		COUNTER TOP HOT SHOWCASE		
	DESCRIPTION		CNZ-90 (HOT)		
<p style="writing-mode: vertical-rl; transform: rotate(180deg);">CABINET</p>	<p style="writing-mode: vertical-rl; transform: rotate(180deg);">DIMENSIONS</p>		W	D	H
		EXTERNAL	900	510	750
		INTERNAL			
	EXTERIOR	Color Panel □			
	INTERIOR	Glass			
SHELVE	Glass * 2 PLUS Base				
DOOR	Sliding Glass Door * 2				
<p style="writing-mode: vertical-rl; transform: rotate(180deg);">HEATING CYCLE</p>	OUTPUT				
	FAN	FAN : 5548152,20W*1			
	POWER	220-240V 50/60HZ			
	CONTROLLER	THERMOSTAT			
	CONDENSOR	FIN TUBE FORCED AIR			
HEATING PERFORMANCE	INTERNAL TEMP : 65 °C				
WEIGHT	110 Kgs				
PRICE FOB MANILA					

Exclusive Philippine Distributor:

STA. ANA IMPORT EXPORT INC.

3874 Macabulos St., Bangkal, Makati City, Philippines, 1233

Tel Nos. 889-0040, 889-0049, 889-0051, and 843-1322

Fax No. 889-0050

Email: Kinco@eastern.com.ph



		PRODUCT NAME		CONFECTIONERY SHOWCASE		
		DESCRIPTION		C3-120 / 180		
CABINET	DIMENSIONS		W	D	H	
		EXTERNAL	120 / 180	700	1170	
	INTERNAL					
	EXTERIOR	SS and Glass				
	INTERIOR	Glass				
	SHELVE	Glass * 2 PLUS Base				
	DOOR	Sliding Glass Door * 2				
REFRIGERATION CYCLE	COMPRESSOR	SC18G Danfoss				
	OUTPUT	7300 / 8100 BTU				
	FREON	R134A				
	EVAPORATOR	FIN TUBE FORCED CIRCULATION				
	FAN	EVAPORATOR FAN : YZF10-20*1 CONDENSOR FAN : 5548152,20W*1				
	POWER	220-240V 50/60HZ				
	CONTROLLER	TL-550				
	CONDENSOR	FIN TUBE FORCED AIR				
	COOLING PERFORMANCE	INTERNAL TEMP : 3 ~ 6°C INTERNAL RH : 70~80%				
	WEIGHT	150 / 170 Kgs				
	PRICE FOB MANILA					

Exclusive Philippine Distributor:

STA. ANA IMPORT EXPORT INC.

3874 Macabulos St., Bangkal, Makati City, Philippines, 1233

Tel Nos. 889-0040, 889-0049, 889-0051, and 843-1322

Fax No. 889-0050

Email: Kinco@eastern.com.ph



Refrigerated and Ambient

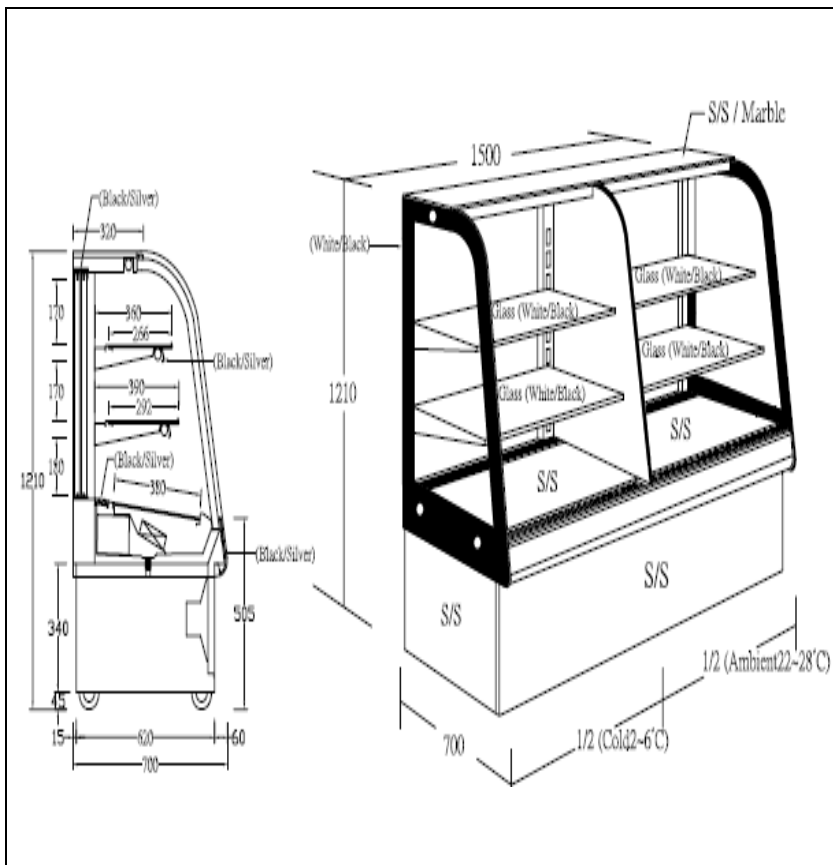

PRODUCT NAME		CONFECTIONERY SHOWCASE		
DESCRIPTION		RZ3-150C (Half Refrigerated/Ambient)		
CABINET	DIMENSIONS	W	D	H
		EXTERNAL	150	700
	INTERNAL			
EXTERIOR		S/S and Glass		
INTERIOR		Glass		
SHELVE		Glass * 2 PLUS Base		
DOOR		Sliding Glass Door * 2		
REFRIGERATION CYCLE	COMPRESSOR	SG18G (Danfoss)		
	OUTPUT	7300 BTU		
	FREON	R134A		
	EVAPORATOR	FIN TUBE FORCED CIRCULATION		
	FAN	EVAPORATOR FAN : YZF10-20*1 CONDENSOR FAN : 5548152,20W*1		
	POWER	220-240V 50/60HZ		
	CONTROLLER	TL-550		
CONDENSOR	FIN TUBE FORCED AIR			
COOLING PERFORMANCE	INTERNAL TEMP : 3 ~ 6°C INTERNAL RH : 70~80%			
WEIGHT	145 Kgs			
PRICE FOB MANILA				

Exclusive Philippine Distributor:

STA. ANA IMPORT EXPORT INC.

3874 Macabulos St., Bangkal, Makati City, Philippines, 1233

Tel Nos. 889-0040, 889-0049, 889-0051, and 843-1322

Fax No. 889-0050

Email: Kinco@eastern.com.ph



All Refrigerated



	PRODUCT NAME		CONFECTIONERY SHOWCASE		
	DESCRIPTION		RZ3-180 All Refrigerated		
	DIMENSIONS		W	D	H
		EXTERNAL	1800	700	1210
	INTERNAL				
CABINET	EXTERIOR	S/S and Glass			
	INTERIOR	Glass			
	SHELVE	Glass * 2 PLUS Base			
	DOOR	Sliding Glass Door * 2			
REFRIGERATION CYCLE	COMPRESSOR	T6220GK Embraco			
	OUTPUT	8100 BTU			
	FREON	R134A			
	EVAPORATOR	FIN TUBE FORCED CIRCULATION			
	FAN	EVAPORATOR FAN : YZF10-20*1 CONDENSOR FAN : 5548152,20W*1			
	POWER	220-240V 50/60HZ			
	CONTROLLER	TL-550			
	CONDENSOR	FIN TUBE FORCED AIR			
COOLING PERFORMANCE	INTERNAL TEMP : 3 ~ 6°C INTERNAL RH : 70~80%				
WEIGHT	175 Kgs				
PRICE FOB MANILA					

Exclusive Philippine Distributor:

STA. ANA IMPORT EXPORT INC.

3874 Macabulos St., Bangkal, Makati City, Philippines, 1233

Tel Nos. 889-0040, 889-0049, 889-0051, and 843-1322

Fax No. 889-0050

Email: Kinco@eastern.com.ph



Refrigerated and Ambient Showcase



		PRODUCT NAME		CONFECTIONERY SHOWCASE		
		DESCRIPTION		RZ4-150C		
CABINET	DIMENSIONS		W	D	H	
		EXTERNAL	150	700	1350	
		INTERNAL				
	EXTERIOR	S/S and Glass				
	INTERIOR	Glass				
	SHELVE	Glass * 3 PLUS Base				
	DOOR	Sliding Glass Door * 2				
REFRIGERATION CYCLE	COMPRESSOR	SC18G Danfoss				
	OUTPUT	7300 BTU				
	FREON	R134A				
	EVAPORATOR	FIN TUBE FORCED CIRCULATION				
	FAN	EVAPORATOR FAN : YZF10-20*1 CONDENSOR FAN : 5548152,20W*1				
	POWER	220-240V 50/60HZ				
	CONTROLLER	TL-550				
CONDENSOR	FIN TUBE FORCED AIR					
COOLING PERFORMANCE		INTERNAL TEMP : 3 ~ 6°C INTERNAL RH : 70~80%				
WEIGHT		160 Kgs				
PRICE FOB MANILA						

Exclusive Philippine Distributor:

STA. ANA IMPORT EXPORT INC.

3874 Macabulos St., Bangkal, Makati City, Philippines, 1233

Tel Nos. 889-0040, 889-0049, 889-0051, and 843-1322

Fax No. 889-0050

Email: Kinco@eastern.com.ph



All Refrigerated 4, 5 and 6 Feet



		PRODUCT NAME		CONFECTIONERY SHOWCASE	
		DESCRIPTION		RZ4-120 / 150 / 180	
CABINET	DIMENSIONS		W	D	H
		EXTERNAL	120 / 150 / 180	700	1350
		INTERNAL			
	EXTERIOR	S/S and Glass			
	INTERIOR	Glass			
	SHELVE	Glass * 3 PLUS Base			
	DOOR	Sliding Glass Door * 2			
REFRIGERATION CYCLE	COMPRESSOR	6220GK / 6222GK EMBRACO			
	OUTPUT	8100 / 9800 BTU			
	FREON	R134A			
	EVAPORATOR	FIN TUBE FORCED CIRCULATION			
	FAN	EVAPORATOR FAN : YZF10-20*1 CONDENSOR FAN : 5548152,20W*1			
	POWER	220-240V 50/60HZ			
	CONTROLLER	TL-550			
CONDENSOR	FIN TUBE FORCED AIR				
COOLING PERFORMANCE	INTERNAL TEMP : 3 ~ 6°C INTERNAL RH : 70~80%				
WEIGHT	130 / 145 / 165 Kgs				
PRICE FOB MANILA					

Exclusive Philippine Distributor:

STA. ANA IMPORT EXPORT INC.

3874 Macabulos St., Bangkal, Makati City, Philippines, 1233

Tel Nos. 889-0040, 889-0049, 889-0051, and 843-1322

Fax No. 889-0050

Email: Kinco@eastern.com.ph



Front and Rear Sliding Doors

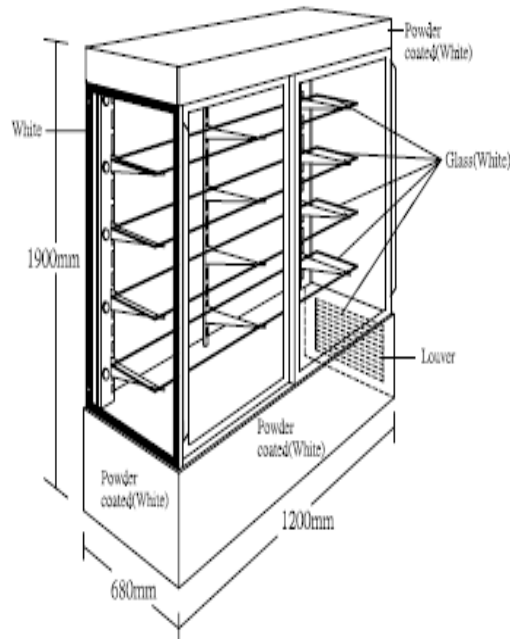
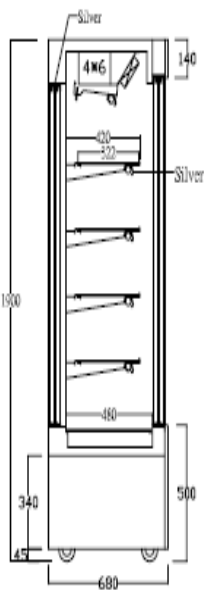

PRODUCT NAME		CONFECTIONERY SHOWCASE		
DESCRIPTION		C5-120FB		
DIMENSIONS		W	D	H
	EXTERNAL	120	680	1900
	INTERNAL			
CABINET	EXTERIOR	Color Panel and Glass		
	INTERIOR	Glass		
	SHELVE	Glass * 4 PLUS Base		
	DOOR	Sliding Glass Door * 4 (Front □Rear)		
REFRIGERATION CYCLE	COMPRESSOR	SC18G Danfoss		
	OUTPUT	7300 BTU		
	FREON	R134A		
	EVAPORATOR	FIN TUBE FORCED CIRCULATION		
	FAN	EVAPORATOR FAN : YZF10-20*1 CONDENSOR FAN : 5548152,20W*1		
	POWER	220-240V 50/60HZ		
	CONTROLLER	TL-550		
	CONDENSOR	FIN TUBE FORCED AIR		
COOLING PERFORMANCE	INTERNAL TEMP : 3 ~ 6°C INTERNAL RH : 70~80%			
WEIGHT	150 Kgs			
PRICE FOB MANILA				

Exclusive Philippine Distributor:

STA. ANA IMPORT EXPORT INC.

3874 Macabulos St., Bangkal, Makati City, Philippines, 1233

Tel Nos. 889-0040, 889-0049, 889-0051, and 843-1322

Fax No. 889-0050

Email: Kinco@eastern.com.ph

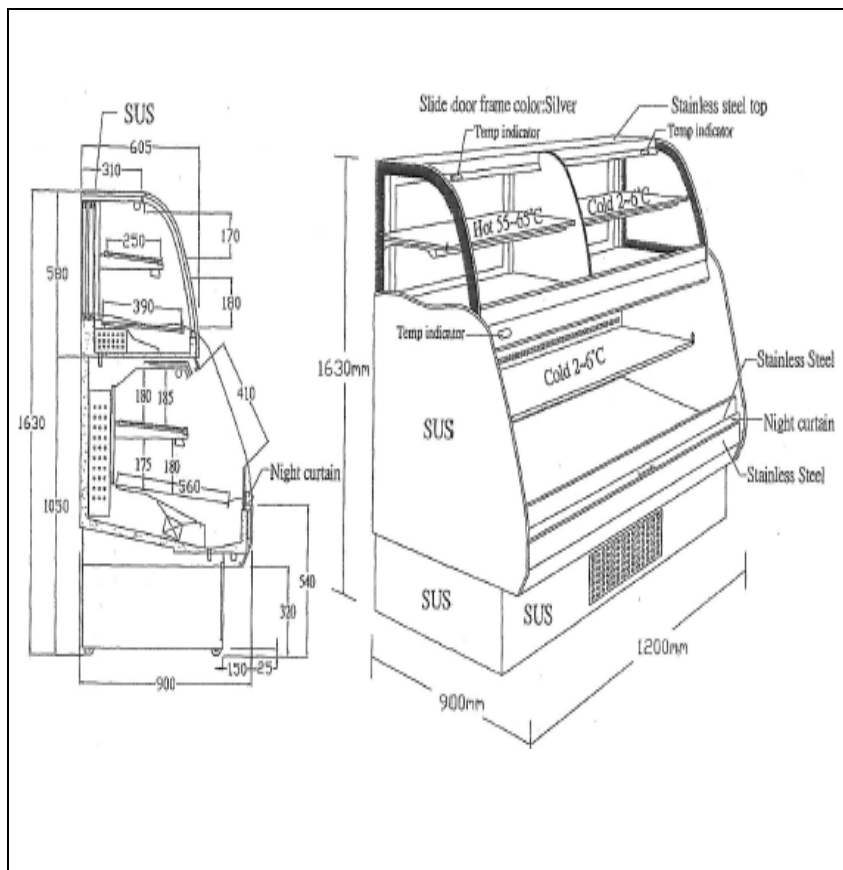

PRODUCT NAME		CONFECTIONERY SHOWCASE			
DESCRIPTION		SK3-120			
CABINET	DIMENSIONS		W	D	H
		EXTERNAL	120	900	1630
		INTERNAL			
EXTERIOR		SS and Glass			
INTERIOR		Glass			
SHELVE		Glass * 1 PLUS Base			
DOOR		Sliding Glass Door * 2			
REFRIGERATION CYCLE	COMPRESSOR	SC18G and SC15G Danfoss			
	OUTPUT	7300 BTU			
	FREON	R134A			
	EVAPORATOR	FIN TUBE FORCED CIRCULATION			
	FAN	EVAPORATOR FAN : YZF10-20*1 CONDENSOR FAN : 5548152,20W*1			
	POWER	220-240V 50/60HZ			
	CONTROLLER	TL-550			
CONDENSOR		FIN TUBE FORCED AIR			
COOLING PERFORMANCE		INTERNAL TEMP : 3 ~ 6°C INTERNAL RH : 70~80%			
WEIGHT		180 Kgs			
PRICE FOB MANILA					

Exclusive Philippine Distributor:

STA. ANA IMPORT EXPORT INC.

3874 Macabulos St., Bangkal, Makati City, Philippines, 1233

Tel Nos. 889-0040, 889-0049, 889-0051, and 843-1322

Fax No. 889-0050

Email: Kinco@eastern.com.ph



KJA – FUR1200

Features

1. Compressor Deck can be pulled outward for easy maintenance, and servicing purposes
2. Forced Evaporation
3. Doors are interchangeable
4. Castors are interchangeable to standard legs
5. Environmental Friendly Refrigerant R134a



	PRODUCT NAME		UNDERCOUNTER CHILLER		
	DESCRIPTION		KJA-FUR1200		
	DIMENSIONS		W	D	H
		EXTERNAL	1200	750	800
		INTERNAL			
	CABINET	EXTERIOR	BODY	SUS 304 (0.5)	
			TOP	SUS 304 (0.8)	
		INTERIOR	SUS 304 (0.4)		
		INSULATION	PU		
	DOOR	S/S DOORS*2			
REFRIGERATION CYCLE	COMPRESSOR	SC10G (Danfoss)			
	OUTPUT	1237W			
	FREON	R134A			
	EVAPORATOR	FIN TUBE FORCED CIRCULATION			
	FAN	EVAPORATOR FAN : DP201A*2 CONDENSOR FAN : 5548152,20W*1			
	POWER	220-240V 50/60HZ			
	CONTROLLER	TL-550			
	CONDENSOR	FIN TUBE FORCED AIR			
COOLING PERFORMANCE	INTERNAL TEMP : 0 ~ 4°C INTERNAL RH : 70~80%				
WEIGHT	80kg				
POWER CONSUMPTION	6.7 KW-hr				

Exclusive Philippine Distributor:

STA. ANA IMPORT EXPORT INC.

3874 Macabulos St., Bangkal, Makati City, Philippines, 1233

Tel Nos. 889-0040, 889-0049, 889-0051, and 843-1322

Fax No. 889-0050

Email: Kinco@eastern.com.ph



KJA – FUF1200

Features

1. Compressor Deck can be pulled outward for easy maintenance, and servicing purposes
2. Forced Evaporation
3. Doors are interchangeable
4. Castors are interchangeable to standard legs
5. Environmental Friendly Refrigerant R404a



		PRODUCT NAME		UNDERCOUNTER FREEZER	
		DESCRIPTION		KJA-FUF1200	
CABINET	DIMENSIONS		W	D	H
		EXTERNAL	1200	750	800
		INTERNAL			
	EXTERIOR	BODY	SUS 304 (0.5)		
		TOP	SUS 304 (0.8)		
	INTERIOR	SUS 304 (0.4)			
	INSULATION	PU			
DOOR	S/S DOORS*2				
REFRIGERATION CYCLE	COMPRESSOR	SC10G (Danfoss)			
	OUTPUT	516W			
	FREON	R404A			
	EVAPORATOR	FIN TUBE FORCED CIRCULATION			
	FAN	EVAPORATOR FAN : DP201A*2 CONDENSOR FAN : 5548152,20W*1			
	POWER	220-240V 50/60HZ			
	CONTROLLER	TL-660			
	CONDENSOR	FIN TUBE FORCED AIR			
COOLING PERFORMANCE	INTERNAL TEMP : -18 ~ -22°C INTERNAL RH : 50~60%				
WEIGHT	80kg				
POWER CONSUMPTION	8 KW-hr				

Exclusive Philippine Distributor:

STA. ANA IMPORT EXPORT INC.

3874 Macabulos St., Bangkal, Makati City, Philippines, 1233

Tel Nos. 889-0040, 889-0049, 889-0051, and 843-1322

Fax No. 889-0050

Email: Kinco@eastern.com.ph



KJA – FUR1500

Features

1. Compressor Deck can be pulled outward for easy maintenance, and servicing purposes
2. Forced Evaporation
3. Doors are interchangeable
4. Castors are interchangeable to standard legs
5. Environmental Friendly Refrigerant R134a

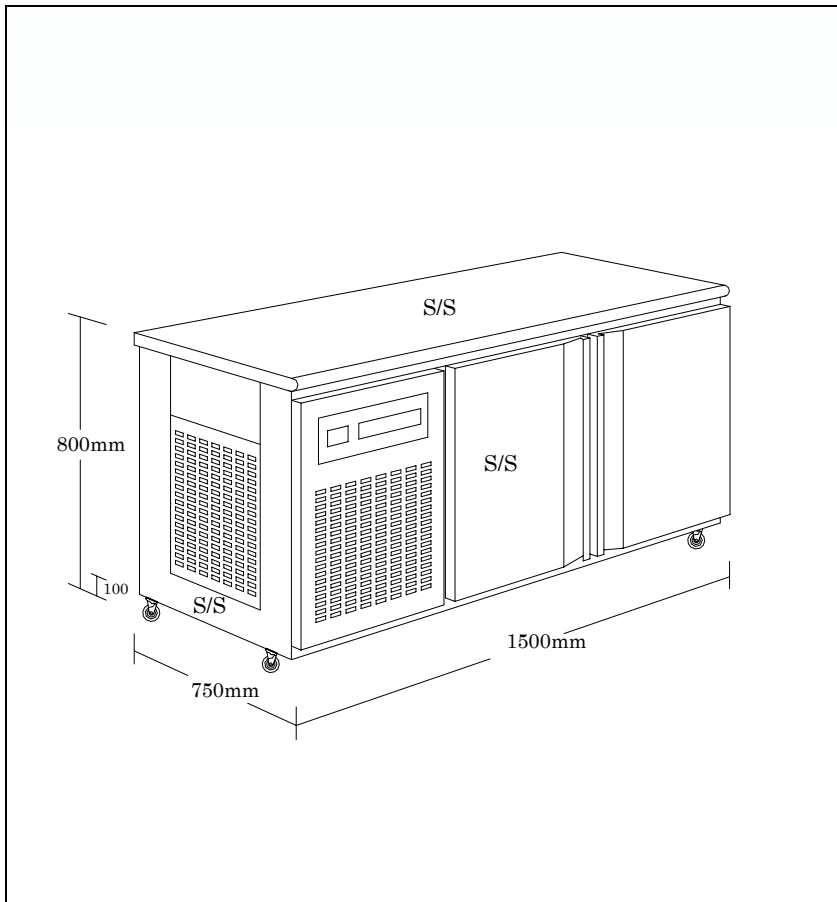

PRODUCT NAME		UNDERCOUNTER CHILLER			
DESCRIPTION		KJA-FUR1500			
CABINET	DIMENSIONS	W	D	H	
		EXTERNAL	1500	750	800
		INTERNAL			
	EXTERIOR	BODY	SUS 304 (0.5)		
		TOP	SUS 304 (0.8)		
	INTERIOR	SUS 304 (0.4)			
	INSULATION	PU			
	DOOR	S/S DOORS*2			
REFRIGERATION CYCLE	COMPRESSOR	SC12G (Danfoss)			
	OUTPUT	1823W			
	FREON	R134A			
	EVAPORATOR	FIN TUBE FORCED CIRCULATION			
	FAN	EVAPORATOR FAN : DP201A*2 CONDENSOR FAN : 5548152,20W*1			
	POWER	220-240V 50/60HZ			
	CONTROLLER	TL-550			
	CONDENSOR	FIN TUBE FORCED AIR			
COOLING PERFORMANCE	INTERNAL TEMP : 0 ~ 4°C INTERNAL RH : 70~80%				
WEIGHT	100kg				
POWER CONSUMPTION	9.2 KW-hr				

Exclusive Philippine Distributor:

STA. ANA IMPORT EXPORT INC.

3874 Macabulos St., Bangkal, Makati City, Philippines, 1233

Tel Nos. 889-0040, 889-0049, 889-0051, and 843-1322

Fax No. 889-0050

Email: Kinco@eastern.com.ph



KJA – FUF1500

Features

1. Compressor Deck can be pulled outward for easy maintenance, and servicing purposes
2. Forced Evaporation
3. Doors are interchangeable
4. Castors are interchangeable to standard legs
5. Environmental Friendly Refrigerant R404

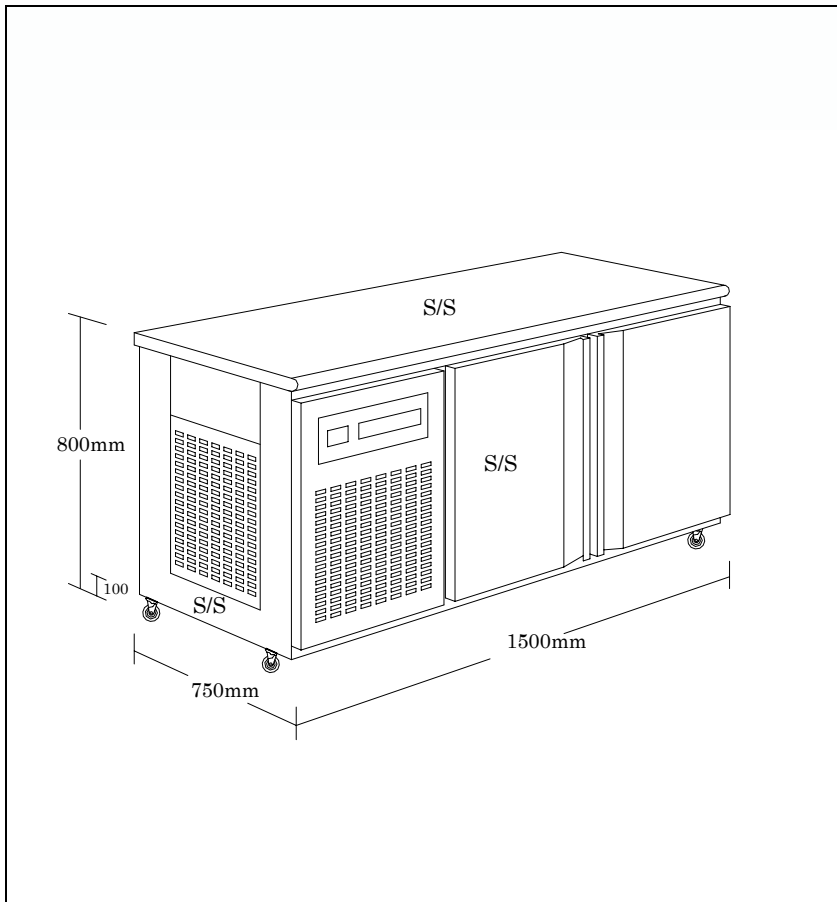

PRODUCT NAME		UNDERCOUNTER FREEZER		
DESCRIPTION		KJA-FUF1500		
DIMENSIONS		W	D	H
	EXTERNAL	1500	750	800
	INTERNAL			
CABINET	EXTERIOR	BODY	SUS 304 (0.5)	
		TOP	SUS 304 (0.8)	
	INTERIOR	SUS 304 (0.4)		
	INSULATION	PU		
DOOR	S/S DOORS*2			
REFRIGERATION CYCLE	COMPRESSOR	SC12CL (Danfoss)		
	OUTPUT	696W		
	FREON	R404		
	EVAPORATOR	FIN TUBE FORCED CIRCULATION		
	FAN	EVAPORATOR FAN : DP201A*2 CONDENSOR FAN : 5548152,20W*1		
	POWER	220-240V 50/60HZ		
	CONTROLLER	TL-550		
CONDENSOR	FIN TUBE FORCED AIR			
COOLING PERFORMANCE	INTERNAL TEMP : -18 to -22 INTERNAL RH : 50~60%			
WEIGHT	100kg			
POWER CONSUMPTION	10.2 KW-hr			

Exclusive Philippine Distributor:

STA. ANA IMPORT EXPORT INC.

3874 Macabulos St., Bangkal, Makati City, Philippines, 1233

Tel Nos. 889-0040, 889-0049, 889-0051, and 843-1322

Fax No. 889-0050

Email: Kinco@eastern.com.ph



KJA – FUR1800

Features

1. Compressor Deck can be pulled outward for easy maintenance, and servicing purposes
2. Forced Evaporation
3. Doors are interchangeable
4. Castors are interchangeable to standard legs
5. Environmental Friendly Refrigerant R134a

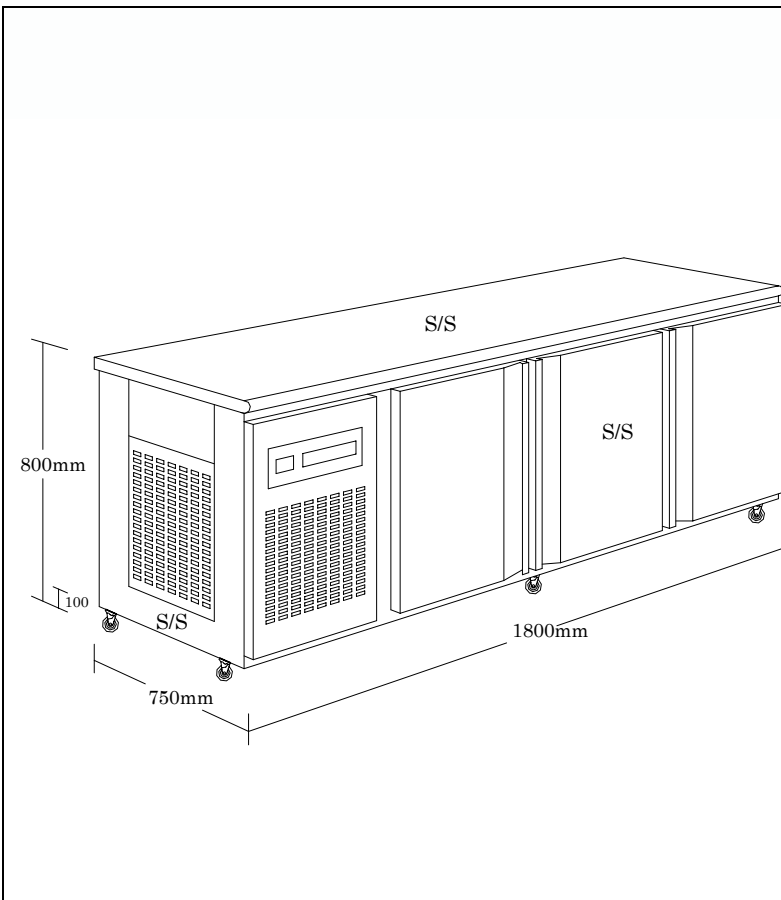

PRODUCT NAME		UNDERCOUNTER CHILLER		
DESCRIPTION		KJA-FUR1800		
DIMENSIONS		W	D	H
	EXTERNAL	1800	750	800
	INTERNAL			
CABINET	EXTERIOR	BODY	SUS 304 (0.4)	
		TOP	SUS 304 (0.8)	
	INTERIOR	SUS 304 (0.4)		
	INSULATION	PU		
	DOOR	S/S DOORS*3		
	REFRIGERATION CYCLE	COMPRESSOR	SC12G (Danfoss)	
OUTPUT		1823W		
FREON		R134A		
EVAPORATOR		FIN TUBE FORCED CIRCULATION		
FAN		EVAPORATOR FAN : DP201A*2 CONDENSOR FAN : 5548152,20W*1		
POWER		220-240V 50/60HZ		
CONTROLLER		TL-550		
CONDENSOR		FIN TUBE FORCED AIR		
COOLING PERFORMANCE		INTERNAL TEMP : 0 ~ 4°C INTERNAL RH : 70~80%		
WEIGHT	120kg			
POWER CONSUMPTION	11.3 KW-hr			

Exclusive Philippine Distributor:

STA. ANA IMPORT EXPORT INC.

3874 Macabulos St., Bangkal, Makati City, Philippines, 1233

Tel Nos. 889-0040, 889-0049, 889-0051, and 843-1322

Fax No. 889-0050

Email: Kinco@eastern.com.ph



KJA – FUF1800

Features

1. Compressor Deck can be pulled outward for easy maintenance, and servicing purposes
2. Forced Evaporation
3. Doors are interchangeable
4. Castors are interchangeable to standard legs
5. Environmental Friendly Refrigerant R404

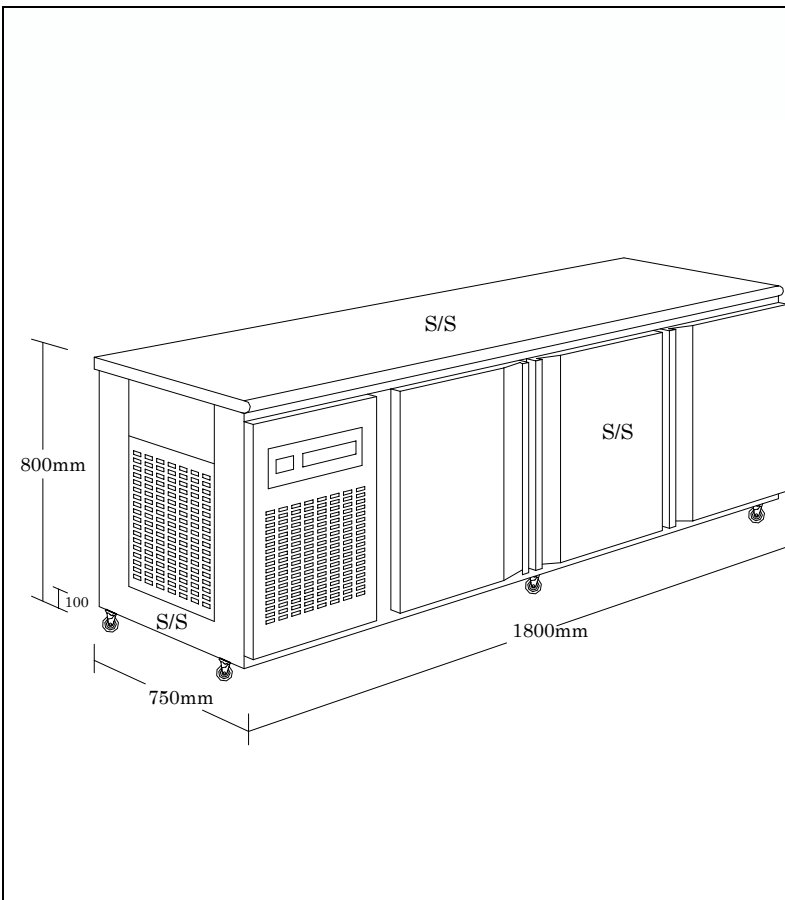
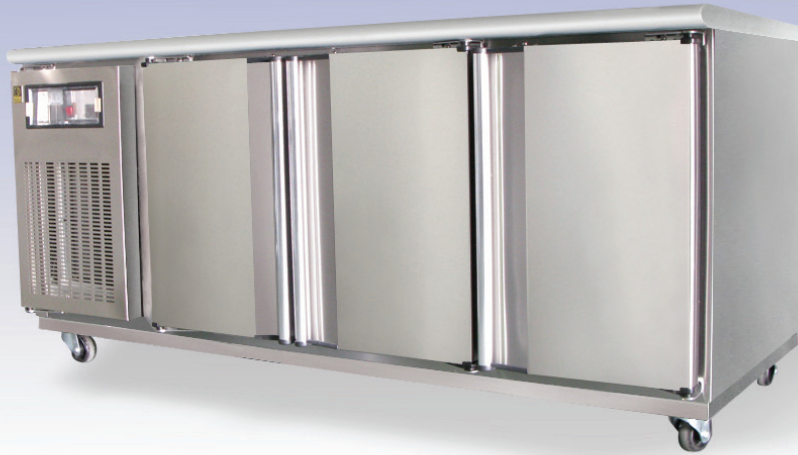

PRODUCT NAME		UNDERCOUNTER FREEZER		
DESCRIPTION		KJA-FUR1800		
DIMENSIONS		W	D	H
	EXTERNAL	1800	750	800
	INTERNAL			
CABINET	EXTERIOR	BODY	SUS 304 (0.5)	
		TOP	SUS 304 (0.8)	
	INTERIOR	SUS 304 (0.4)		
	INSULATION	PU		
	DOOR	S/S DOORS*3		
	REFRIGERATION CYCLE	COMPRESSOR	SC12CL (Danfoss)	
	OUTPUT	66W		
	FREON	R404A		
	EVAPORATOR	FIN TUBE FORCED CIRCULATION		
	FAN	EVAPORATOR FAN : DP201A*2 CONDENSOR FAN : 5548152,20W*1		
	POWER	220-240V 50/60HZ		
	CONTROLLER	TL-550		
	CONDENSOR	FIN TUBE FORCED AIR		
COOLING PERFORMANCE		INTERNAL TEMP : -18 - -22 INTERNAL RH : 50~60%		
WEIGHT		120kg		
POWER CONSUMPTION		11.3 KW-hr		

Exclusive Philippine Distributor:

STA. ANA IMPORT EXPORT INC.

3874 Macabulos St., Bangkal, Makati City, Philippines, 1233

Tel Nos. 889-0040, 889-0049, 889-0051, and 843-1322

Fax No. 889-0050

Email: Kinco@eastern.com.ph



KJA-CR1260

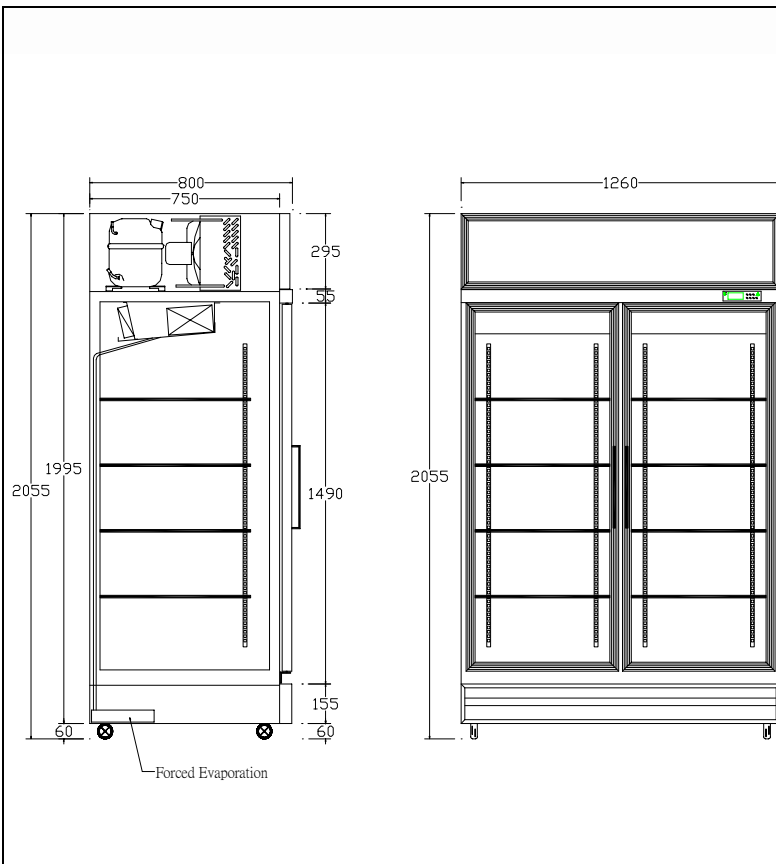

PRODUCT NAME		KINCO 2 Doors Glass Chiller			
DESCRIPTION		KJA-CR1260			
CABINET	DIMENSIONS		W	D	H
		EXTERNAL	1260	800	2055
		INTERNAL			
EXTERIOR		Powder coated(White)			
INTERIOR		Powder coated(White)			
INSULATION		PU			
DOOR		GLASS DOORS*2			
REFRIGERATION CYCLE	COMPRESSOR	FFI12HBX(Embraco)			
	OUTPUT	1550W			
	FREON	R134A			
	EVAPORATOR	FIN TUBE FORCED CIRCULATION			
	FAN	EVAPORATOR FAN : DP201A*3 CONDENSOR FAN : 5548152,20W*1			
	POWER	220-240V 50/60HZ			
	CONTROLLER	TL-290			
CONDENSOR		FIN TUBE FORCED AIR			
COOLING PERFORMANCE		INTERNAL TEMP : 0 ~ 4°C INTERNAL RH : 70~80%			
WEIGHT		170kg			
POWER CONSUMPTION		14.2KW-hr			

Exclusive Philippine Distributor:

STA. ANA IMPORT EXPORT INC.

3874 Macabulos St., Bangkal, Makati City, Philippines, 1233

Tel Nos. 889-0040, 889-0049, 889-0051, and 843-1322

Fax No. 889-0050

Email: Kinco@eastern.com.ph



KJA-CR1880

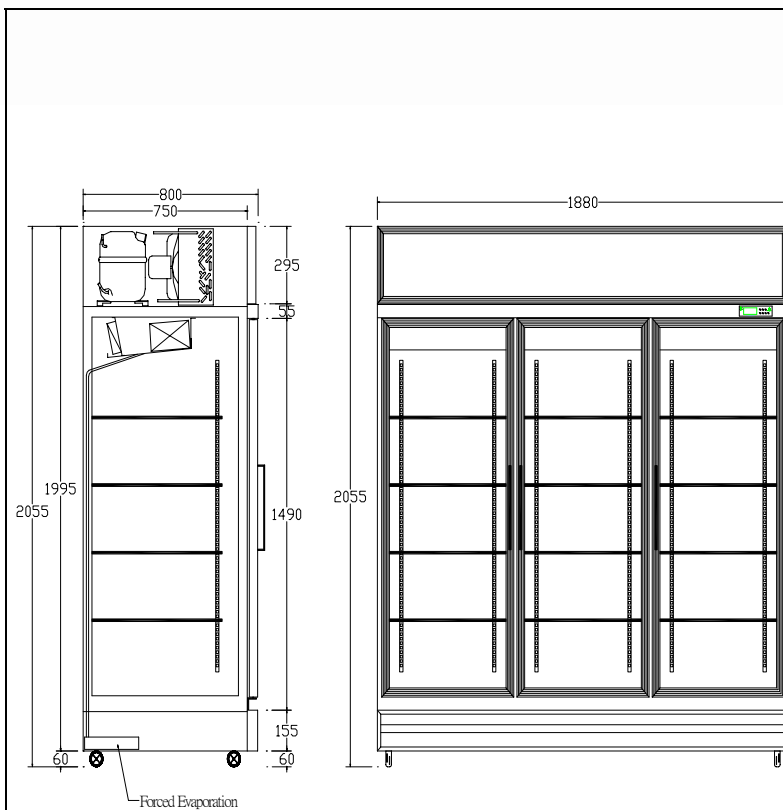

PRODUCT NAME		KINCO 3 Glass Doors Chiller		
DESCRIPTION		KJA-CR 1880		
DIMENSIONS		W	D	H
	EXTERNAL	1880	800	2055
	INTERNAL			
CABINET	EXTERIOR	Powder coated(White)		
	INTERIOR	Powder coated(White)		
	INSULATION	PU		
	DOOR	GLASS DOORS*3		
	REFRIGERATION CYCLE	COMPRESSOR	NE9213GK(Embraco)	
	OUTPUT	1729W		
	FREON	R404A		
	EVAPORATOR	FIN TUBE FORCED CIRCULATION		
	FAN	EVAPORATOR FAN :DP201A*4 CONDENSOR FAN : 5548152,20W*1		
	POWER	220-240V 50/ 60HZ		
	CONTROLLER	TL-290		
	CONDENSOR	FIN TUBE FORCED AIR		
COOLING PERFORMANCE		INTERNAL TEMP : 0 ~ 4°C INTERNAL RH : 70~80%		
WEIGHT		210kg		
POWER CONSUMPTION		14.2 KW-hr		

Exclusive Philippine Distributor:

STA. ANA IMPORT EXPORT INC.

3874 Macabulos St., Bangkal, Makati City, Philippines, 1233

Tel Nos. 889-0040, 889-0049, 889-0051, and 843-1322

Fax No. 889-0050

Email: Kinco@eastern.com.ph



KJA-CF1260

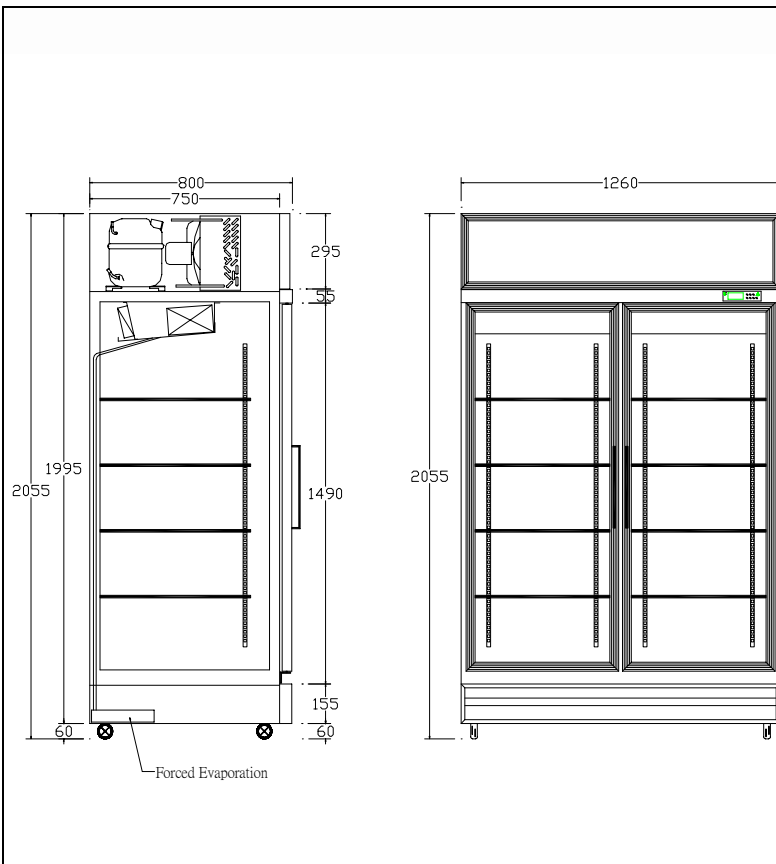

PRODUCT NAME		KINCO 2 Glass Doors Freezer			
DESCRIPTION		KJA-CF1260			
CABINET	DIMENSIONS		W	D	H
		EXTERNAL	1260	800	2055
		INTERNAL			
EXTERIOR		Powder coated(White)			
INTERIOR		Powder coated(White)			
INSULATION		PU			
DOOR		GLASS DOORS*2			
REFRIGERATION CYCLE	COMPRESSOR	NJ2212GK(Embraco)			
	OUTPUT	1550W			
	FREON	R-404			
	EVAPORATOR	FIN TUBE FORCED CIRCULATION			
	FAN	EVAPORATOR FAN : DP201A*3 CONDENSOR FAN : 5548152,20W*1			
	POWER	220-240V 50/60HZ			
	CONTROLLER	TL-290			
	CONDENSOR	FIN TUBE FORCED AIR			
COOLING PERFORMANCE		INTERNAL TEMP : -18 - 22C INTERNAL RH : 50 - 60%			
WEIGHT		170kg			
POWER CONSUMPTION		21.2KW-Hr			

Exclusive Philippine Distributor:

STA. ANA IMPORT EXPORT INC.

3874 Macabulos St., Bangkal, Makati City, Philippines, 1233

Tel Nos. 889-0040, 889-0049, 889-0051, and 843-1322

Fax No. 889-0050

Email: Kinco@eastern.com.ph



KJA – FR771

Features

1. Forced Evaporation
2. Doors are interchangeable
3. Castors are interchangeable to standard legs
4. Environmental Friendly Refrigerant R134a

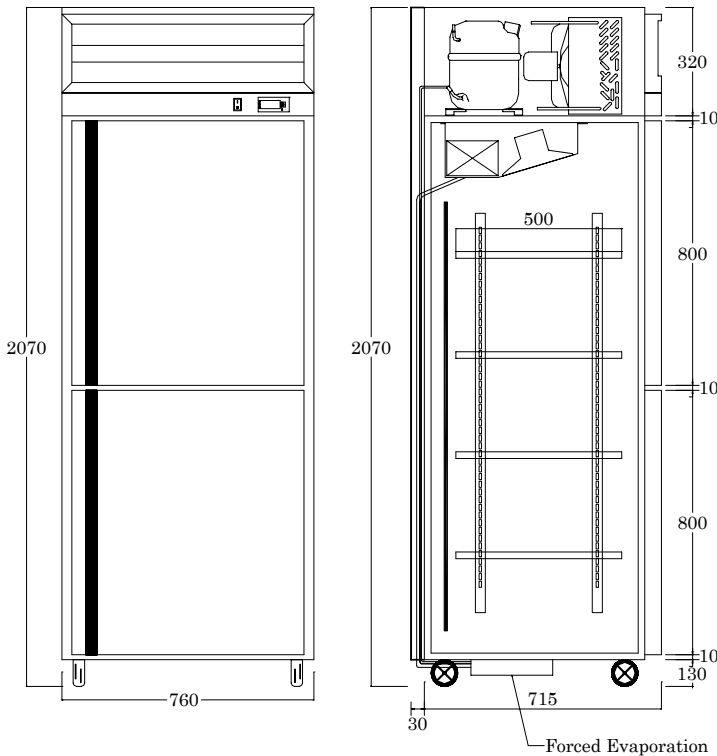

PRODUCT NAME		STAINLESS CHILLER			
DESCRIPTION		KJA-FR771			
CABINET	DIMENSIONS		W	D	H
		EXTERNAL	760	715	2070
		INTERNAL			
EXTERIOR		SUS 430			
INTERIOR		SUS 304			
INSULATION		PU			
DOOR		S/S DOORS*2			
COMPRESSOR		SC12G (Danfoss)			
OUTPUT		1569W			
FREON		R134A			
EVAPORATOR		FIN TUBE FORCED CIRCULATION			
FAN		EVAPORATOR FAN : YZF10-20*1 CONDENSOR FAN : 5548152.20W*1			
POWER		220-240V 50/60HZ			
CONTROLLER		TL-550			
CONDENSOR		FIN TUBE FORCED AIR			
COOLING PERFORMANCE		INTERNAL TEMP : 0 ~ 4°C INTERNAL RH : 70~80%			
WEIGHT		130kg			
POWER CONSUMPTION		14.3 KW-hr			

Exclusive Philippine Distributor:

STA. ANA IMPORT EXPORT INC.

3874 Macabulos St., Bangkal, Makati City, Philippines, 1233

Tel Nos. 889-0040, 889-0049, 889-0051, and 843-1322

Fax No. 889-0050

Email: Kinco@eastern.com.ph



KJA – FF771

Features

1. Forced Evaporation
2. Doors are interchangeable
3. Castors are interchangeable to standard legs
4. Environmental Friendly Refrigerant R404a

	PRODUCT NAME		STAINLESS FREEZER		
	DESCRIPTION		KJA-FF771		
CABINET	DIMENSIONS		W	D	H
		EXTERNAL	760	715	2070
		INTERNAL			
	EXTERIOR	SUS 430			
INTERIOR	SUS 304				
INSULATION	PU				
DOOR	S/S DOORS*2				
REFRIGERATION CYCLE	COMPRESSOR	SC15CL (Danfoss)			
	OUTPUT	773W			
	FREON	R404A			
	EVAPORATOR	FIN TUBE FORCED CIRCULATION			
	FAN	EVAPORATOR FAN : YZF10-20*1 CONDENSOR FAN : 5548152,20W*1			
	POWER	220-240V 60HZ			
	CONTROLLER	TL-660			
	CONDENSOR	FIN TUBE FORCED AIR			
COOLING PERFORMANCE	INTERNAL TEMP : -18 ~ -22°C INTERNAL RH : 50~60%				
WEIGHT	130kg				
POWER CONSUMPTION	14.7 KW-hr				

Exclusive Philippine Distributor:

STA. ANA IMPORT EXPORT INC.

3874 Macabulos St., Bangkal, Makati City, Philippines, 1233

Tel Nos. 889-0040, 889-0049, 889-0051, and 843-1322

Fax No. 889-0050

Email: Kinco@eastern.com.ph



KJA – FR1271

Features

1. Forced Evaporation
2. Doors are interchangeable
3. Castors are interchangeable to standard legs
4. Environmental Friendly Refrigerant R134a

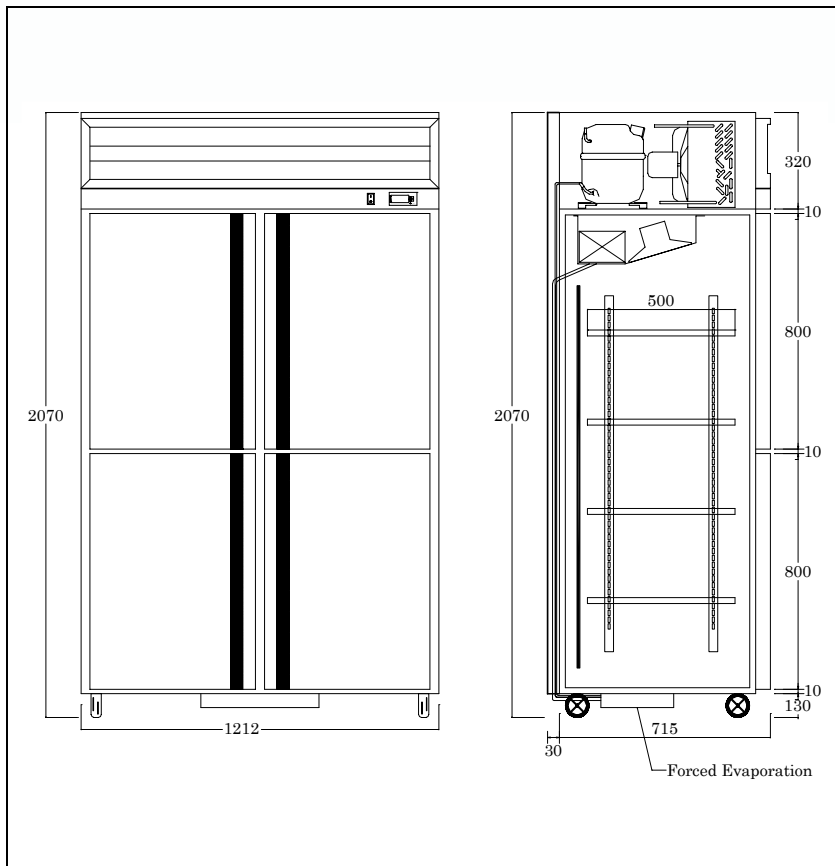

PRODUCT NAME		STAINLESS CHILLER		
DESCRIPTION		KJA-FR1271		
DIMENSIONS		W	D	H
	EXTERNAL	1212	715	2070
	INTERNAL			
CABINET	EXTERIOR	SUS 430		
	INTERIOR	SUS 304		
	INSULATION	PU		
	DOOR	S/S DOORS*4		
REFRIGERATION CYCLE	COMPRESSOR	SC15G (Danfoss)		
	OUTPUT	1823W		
	FREON	R134A		
	EVAPORATOR	FIN TUBE FORCED CIRCULATION		
	FAN	EVAPORATOR FAN : YZF10-20*2 CONDENSOR FAN : 5548152,20W*1		
	POWER	220-240V 50/60HZ		
	CONTROLLER	TL-550		
	CONDENSOR	FIN TUBE FORCED AIR		
COOLING PERFORMANCE		INTERNAL TEMP : 0 ~ 4°C INTERNAL RH : 70~80%		
WEIGHT		170kg		
POWER CONSUMPTION		15.1 KW-hr		

Exclusive Philippine Distributor:

STA. ANA IMPORT EXPORT INC.

3874 Macabulos St., Bangkal, Makati City, Philippines, 1233

Tel Nos. 889-0040, 889-0049, 889-0051, and 843-1322

Fax No. 889-0050

Email: Kinco@eastern.com.ph



KJA – FF1271

Features

1. Forced Evaporation
2. Doors are interchangeable
3. Castors are interchangeable to standard legs
4. Environmental Friendly Refrigerant R404a



		PRODUCT NAME STAINLESS FREEZER			
		DESCRIPTION KJA-FF1271			
	DIMENSIONS		W	D	H
		EXTERNAL	1212	715	2070
	INTERNAL				
CABINET	EXTERIOR	SUS 430			
	INTERIOR	SUS 304			
	INSULATION	PU			
	DOOR	S/S DOORS*4			
REFRIGERATION CYCLE	COMPRESSOR	SC21CL (Danfoss)			
	OUTPUT	903W			
	FREON	R404A			
	EVAPORATOR	FIN TUBE FORCED CIRCULATION			
	FAN	EVAPORATOR FAN : YZF10-20*2 CONDENSOR FAN : 5548152,20W*1			
	POWER	220-240V 60HZ			
	CONTROLLER	TL-660			
	CONDENSOR	FIN TUBE FORCED AIR			
COOLING PERFORMANCE	INTERNAL TEMP : -18 ~ -22°C INTERNAL RH : 50~60%				
WEIGHT	170kg				
POWER CONSUMPTION	15.4 KW-hr				

Exclusive Philippine Distributor:

STA. ANA IMPORT EXPORT INC.

3874 Macabulos St., Bangkal, Makati City, Philippines, 1233

Tel Nos. 889-0040, 889-0049, 889-0051, and 843-1322

Fax No. 889-0050

Email: Kinco@eastern.com.ph



KJA – FF1571

Features

1. Forced Evaporation
2. Castors are interchangeable to standard legs
3. Environmental Friendly Refrigerant R404a



	PRODUCT NAME		WORK TOP		
	DESCRIPTION		KJA-FF1571		
CABINET	DIMENSIONS		W	D	H
		EXTERNAL	1512	715	2045
		INTERNAL			
	EXTERIOR	SUS 430			
	INTERIOR	SUS 304			
INSULATION	PU				
DOOR	S/S DOORS*4				
REFRIGERATION CYCLE	COMPRESSOR	SC21CL(Danfoss)			
	OUTPUT	903W			
	FREON	R404A			
	EVAPORATOR	FIN TUBE FORCED CIRCULATION			
	FAN	EVAPORATOR FAN : YZF10-20*2 CONDENSOR FAN : 5548152,20W*1			
	POWER	220-240V / 50-60HZ 1phase			
	CONTROLLER	TL-660			
	CONDENSOR	FIN TUBE FORCED AIR			
COOLING PERFORMANCE	INTERNAL TEMP : -18~-22°C INTERNAL RH : 50~60%				
WEIGHT	190kg				
POWER CONSUMPTION	15.4 KW-hr				

Exclusive Distributed By :

STA. ANA IMPORT EXPORT INC.

3874-76 Macabulos Street, Bangkal, Makati City 1233
 Tel No. 889-0040, 889-0049, 889-0051, 843-1322, 844-0384
 Email: Kinco@eastern.com.ph



KJA – FR1871

Features

1. Forced Evaporation
2. Doors are interchangeable
3. Castors are interchangeable to standard legs
4. Environmental Friendly Refrigerant R134a

	PRODUCT NAME		STAINLESS CHILLER		
	DESCRIPTION		KJA-FR1871		
	DIMENSIONS		W	D	H
		EXTERNAL	1818	715	2070
		INTERNAL			
	CABINET	EXTERIOR	SUS 430		
		INTERIOR	SUS 304		
		INSULATION	PU		
	REFRIGERATION CYCLE	DOOR	S/S DOORS*6		
		COMPRESSOR	SC21G (Danfoss)		
OUTPUT		2500W			
FREON		R134A			
EVAPORATOR		FIN TUBE FORCED CIRCULATION			
FAN		EVAPORATOR FAN : YZF10-20*3 CONDENSOR FAN : 5548152,20W*1			
POWER		220-240V 50/60HZ			
CONTROLLER		TL-550			
CONDENSOR		FIN TUBE FORCED AIR			
COOLING PERFORMANCE		INTERNAL TEMP : 0 ~ -4 °C INTERNAL RH : 70~80%			
WEIGHT	210kg				
POWER CONSUMPTION	16.6 KW-hr				

Exclusive Philippine Distributor:

STA. ANA IMPORT EXPORT INC.

3874 Macabulos St., Bangkal, Makati City, Philippines, 1233

Tel Nos. 889-0040, 889-0049, 889-0051, and 843-1322

Fax No. 889-0050

Email: Kinco@eastern.com.ph



KJA – FF1871

Features

1. Forced Evaporation
2. Doors are interchangeable
3. Castors are interchangeable to standard legs
4. Environmental Friendly Refrigerant R404a

PRODUCT NAME		STAINLESS FREEZER		
DESCRIPTION		KJA-FF1871		
DIMENSIONS		W	D	H
	EXTERNAL	1818	715	2070
	INTERNAL			
CABINET	EXTERIOR	SUS 430		
	INTERIOR	SUS 304		
	INSULATION	PU		
	DOOR	S/S DOORS*6		
REFRIGERATION CYCLE	COMPRESSOR	NJ2192GK (Embraco)		
	OUTPUT	1126W		
	FREON	R404A		
	EVAPORATOR	FIN TUBE FORCED CIRCULATION		
	FAN	EVAPORATOR FAN : YZF10-20*3 CONDENSOR FAN : 5548152,20W*2		
	POWER	220-240V 60HZ		
	CONTROLLER	TL-660		
	CONDENSOR	FIN TUBE FORCED AIR		
COOLING PERFORMANCE	INTERNAL TEMP : -18 ~ -22°C INTERNAL RH : 50~60%			
WEIGHT	210kg			
POWER CONSUMPTION	18.5 KW-hr			

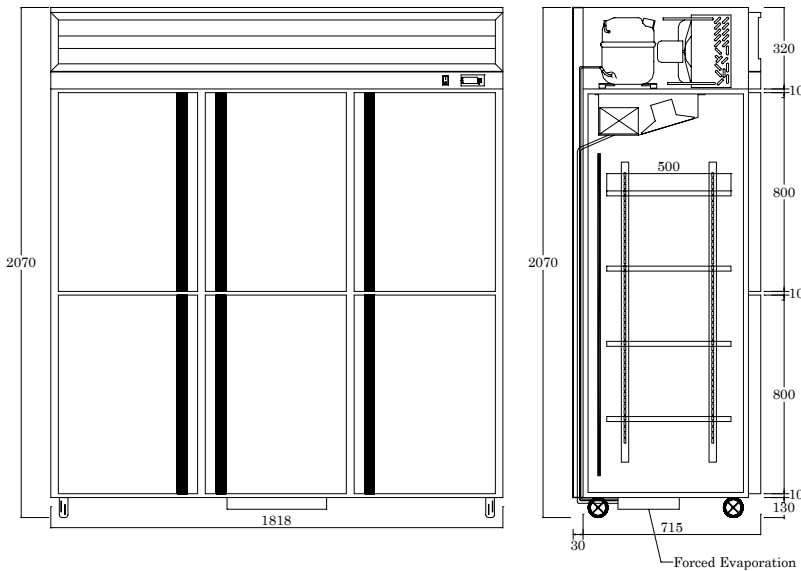

Exclusive Philippine Distributor:

STA. ANA IMPORT EXPORT INC.

3874 Macabulos St., Bangkal, Makati City, Philippines, 1233

Tel Nos. 889-0040, 889-0049, 889-0051, and 843-1322

Fax No. 889-0050

Email: Kinco@eastern.com.ph



KJA – FF771G

Features

1. Forced Evaporation
2. Castors are interchangeable to standard legs
3. Environmental Friendly Refrigerant R404a

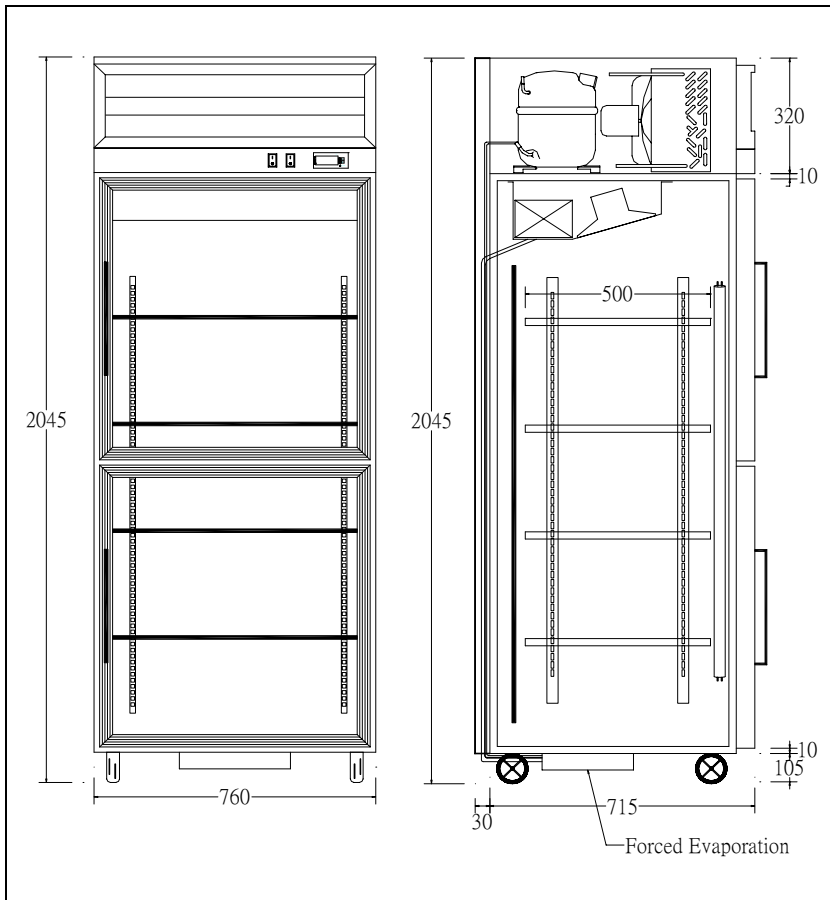

PRODUCT NAME		STAINLESS GLASS DOORS FREEZER		
DESCRIPTION		KJA-FF771G		
DIMENSIONS		W	D	H
	EXTERNAL	760	715	2045
	INTERNAL			
CABINET	EXTERIOR	SUS 430		
	INTERIOR	SUS 304		
	INSULATION	PU		
	DOOR	Glass DOORS*2		
REFRIGERATION CYCLE	COMPRESSOR	SC15CL (Danfoss)		
	OUTPUT	773W		
	FREON	R404A		
	EVAPORATOR	FIN TUBE FORCED CIRCULATION		
	FAN	EVAPORATOR FAN : YZF10-20*1 CONDENSOR FAN : 5548152,20W*1		
	POWER	220-240V 5060HZ		
	CONTROLLER	TL-660		
CONDENSOR	FIN TUBE FORCED AIR			
COOLING PERFORMANCE	INTERNAL TEMP : -18 ~ -22°C INTERNAL RH : 50~60%			
WEIGHT	130kg			
POWER CONSUMPTION	18.3 KW-hr			

Exclusive Philippine Distributor:

STA. ANA IMPORT EXPORT INC.

3874 Macabulos St., Bangkal, Makati City, Philippines, 1233
 Tel Nos. 889-0040, 889-0049, 889-0051, and 843-1322
 Fax No. 889-0050
 Email: Kinco@eastern.com.ph



KJA – FF1271G

Features

1. Forced Evaporation
2. Castors are interchangeable to standard legs
3. Environmental Friendly Refrigerant R404a



	PRODUCT NAME STAINLESS GLASS DOORS FREEZER		
	DESCRIPTION KJA-FF1271G		
	DIMENSIONS	EXTERNAL	INTERNAL
		W 1212	D 715
CABINET		EXTERIOR SUS 430	INTERIOR SUS 304
REFRIGERATION CYCLE		INSULATION PU	DOOR Glass DOORS*4
REFRIGERATION CYCLE		COMPRESSOR SC21CL (Danfoss)	OUTPUT 903W
REFRIGERATION CYCLE		FREON R404A	EVAPORATOR FIN TUBE FORCED CIRCULATION
REFRIGERATION CYCLE		FAN EVAPORATOR FAN : YZF10-20*2 CONDENSOR FAN : 5548152,20W*1	POWER 220-240V 5060HZ
REFRIGERATION CYCLE		CONTROLLER TL-660	CONDENSOR FIN TUBE FORCED AIR
COOLING PERFORMANCE		INTERNAL TEMP : -18 ~ -22°C INTERNAL RH : 50~60%	
WEIGHT		170kg	
POWER CONSUMPTION		19.1 KW-hr	

Exclusive Philippine Distributor:

STA. ANA IMPORT EXPORT INC.

3874 Macabulos St., Bangkal, Makati City, Philippines, 1233

Tel Nos. 889-0040, 889-0049, 889-0051, and 843-1322

Fax No. 889-0050

Email: Kinco@eastern.com.ph



KJA – FR1271G

Features

1. Forced Evaporation
2. Castors are interchangeable to standard legs
3. Environmental Friendly Refrigerant R134a



	PRODUCT NAME		STAINLESS GLASS DOORS CHILLER		
	DESCRIPTION		KJA-FR1271G		
	DIMENSIONS		W	D	H
		EXTERNAL	1212	715	2045
	INTERNAL				
	CABINET	EXTERIOR	SUS 430		
		INTERIOR	SUS 304		
		INSULATION	PU		
		DOOR	Glass DOORS*4		
	REFRIGERATION CYCLE	COMPRESSOR	SC15G (Danfoss)		
		OUTPUT	1823W		
		FREON	R134A		
		EVAPORATOR	FIN TUBE FORCED CIRCULATION		
		FAN	EVAPORATOR FAN : YZF10-20*2 CONDENSOR FAN : 5548152,20W*1		
		POWER	220-240V 50/60HZ		
		CONTROLLER	TL-550		
		CONDENSOR	FIN TUBE FORCED AIR		
	COOLING PERFORMANCE	INTERNAL TEMP : 0 ~ 4°C INTERNAL RH : 70~80%			
	WEIGHT	170kg			
	POWER CONSUMPTION	18.5 KW-hr			

Exclusive Philippine Distributor:

STA. ANA IMPORT EXPORT INC.

3874 Macabulos St., Bangkal, Makati City, Philippines, 1233

Tel Nos. 889-0040, 889-0049, 889-0051, and 843-1322

Fax No. 889-0050

Email: Kinco@eastern.com.ph



431-KEP

Made in Japan

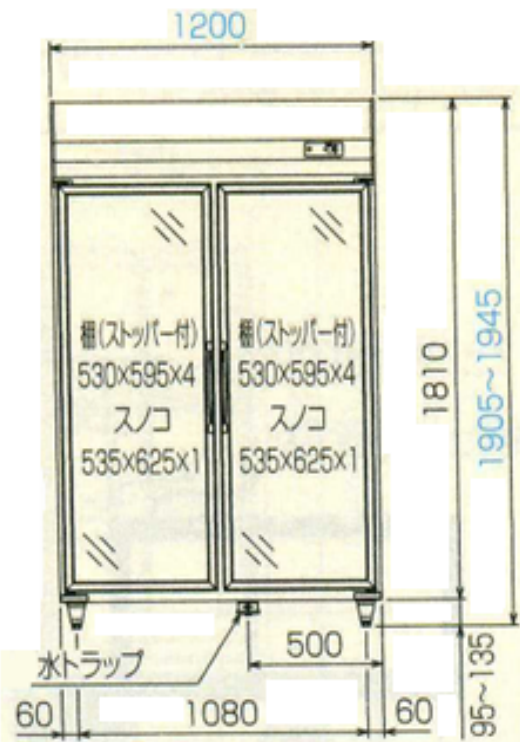

PRODUCT NAME		GLASS DOORS CHILLER			
DESCRIPTION		431-KEP			
CABINET	DIMENSIONS		W	D	H
		EXTERNAL	1200	800	1905
	INTERNAL				
EXTERIOR		SUS 430			
INTERIOR		Hard Plastic			
INSULATION		PU			
DOOR		GLASS DOORS*2			
REFRIGERATION CYCLE	COMPRESSOR	Hitachi, Japan			
	OUTPUT	300W			
	FREON	R22			
	EVAPORATOR	FIN TUBE FORCED CIRCULATION			
	FAN	EVAPORATOR FAN : S12DX10W*2 CONDENSOR FAN : N15103-100V*1			
	POWER	220-240V 50/60HZ By Transformer			
	CONTROLLER	Mechanical			
	CONDENSOR	FIN TUBE FORCED AIR			
COOLING PERFORMANCE		INTERNAL TEMP : 0 ~ 4°C INTERNAL RH : 70~80%			
WEIGHT		170kg			
PRICE					
FOB MANILA					

Exclusive Philippine Distributor:

STA. ANA IMPORT EXPORT INC.

3874 Macabulos St., Bangkal, Makati City, Philippines, 1233

Tel Nos. 889-0040, 889-0049, 889-0051, and 843-1322

Fax No. 889-0050

Email: Kinco@eastern.com.ph



433-FKEP

Made in Japan

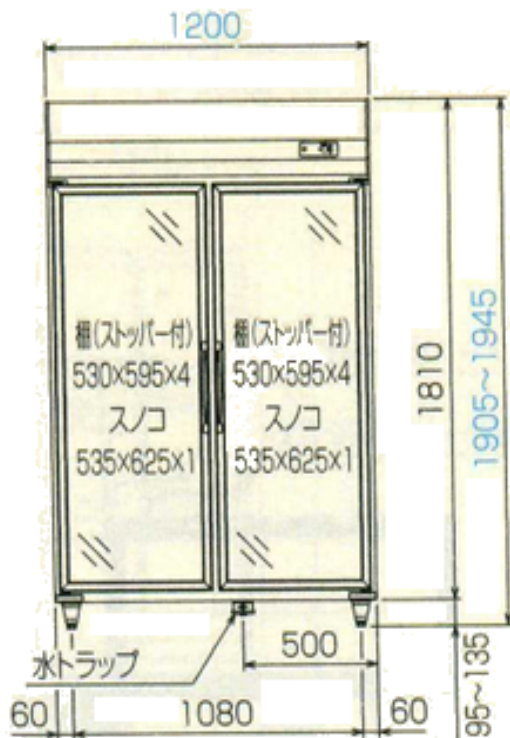

PRODUCT NAME		GLASS DOORS FREEZER		
DESCRIPTION		433-FKEP		
CABINET	DIMENSIONS	W	D	H
		EXTERNAL	1200	800
	INTERNAL			
EXTERIOR		SUS 430		
INTERIOR		Hard Plastic		
INSULATION		PU		
DOOR		GLASS DOORS WITH HEATER*2		
REFRIGERATION CYCLE	COMPRESSOR	Hitachi, Japan		
	OUTPUT	1100W		
	FREON	R22		
	EVAPORATOR	FIN TUBE FORCED CIRCULATION		
	FAN	EVAPORATOR FAN : N2508-200V*2 CONDENSOR FAN : N15108-200V*1		
	POWER	220-240V 50/60HZ 3 Phase		
	CONTROLLER	Mechanical		
	CONDENSOR	FIN TUBE FORCED AIR		
COOLING PERFORMANCE		INTERNAL TEMP : -20~-18C INTERNAL RH : 70~80%		
WEIGHT		170kg		
PRICE				
FOB MANILA				

Exclusive Philippine Distributor:

STA. ANA IMPORT EXPORT INC.

3874 Macabulos St., Bangkal, Makati City, Philippines, 1233

Tel Nos. 889-0040, 889-0049, 889-0051, and 843-1322

Fax No. 889-0050

Email: Kinco@eastern.com.ph



471-S2

Features

- 1. Freezer and Chiller
 - 2. Environmental Friendly Refrigerant
- Made in Japan

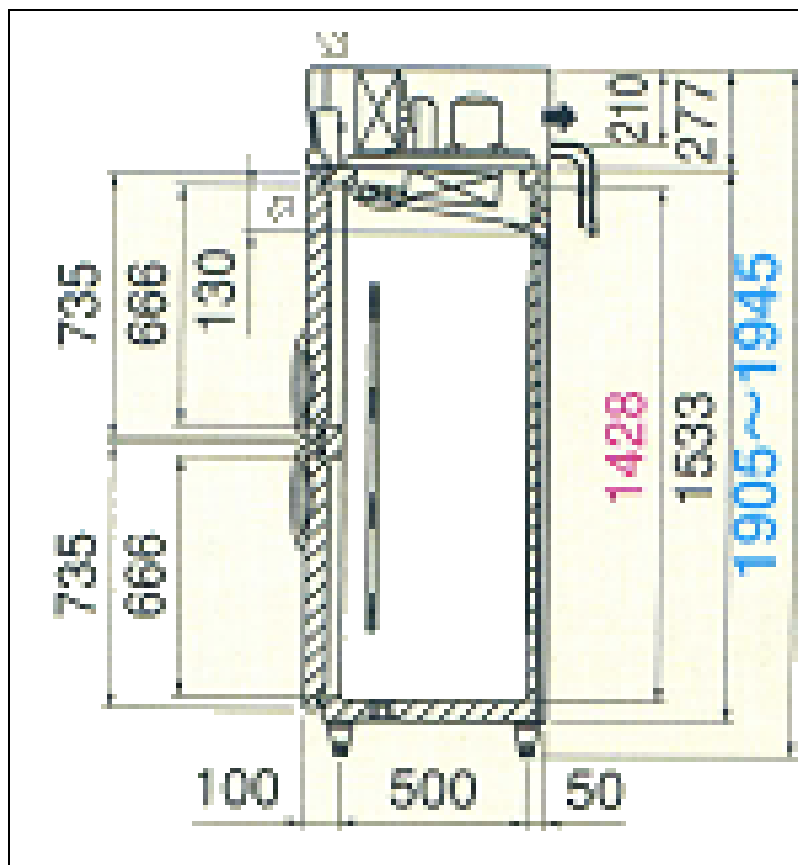

PRODUCT NAME		STAINLESS FREEZER AND CHILLER			
DESCRIPTION		471-S2			
CABINET	DIMENSIONS		W	D	H
		EXTERNAL	1200	800	1905
	INTERNAL				
EXTERIOR		SUS 430			
INTERIOR		Hard Plastic			
INSULATION		PU			
DOOR		Stainless Door * 4			
REFRIGERATION CYCLE	COMPRESSOR	Chiller Hitachi / Freezer Sanyo (JAPAN)			
	OUTPUT	Chiller 200W / Freezer 350W			
	FREON	Chiller R-134A/ Freezer R-404A			
	EVAPORATOR	FIN TUBE FORCED CIRCULATION			
	FAN	EVAPORATOR FAN : S12DX10W*2 CONDENSOR FAN : N15103-100V*1			
	POWER	220-240V 50/60HZ By Transformer			
	CONTROLLER	Digital, Electronic			
	CONDENSOR	FIN TUBE FORCED AIR			
COOLING PERFORMANCE		INTERNAL TEMP : 0 ~ 4°C INTERNAL RH : 70~80%			
WEIGHT		166kg			
PRICE					
FOB MANILA					

Exclusive Philippine Distributor:

STA. ANA IMPORT EXPORT INC.

3874 Macabulos St., Bangkal, Makati City, Philippines, 1233

Tel Nos. 889-0040, 889-0049, 889-0051, and 843-1322

Fax No. 889-0050

Email: Kinco@eastern.com.ph



573-SS Stainless Freezer

Features

SANYO, Japan Compressor

Environmental Friendly Refrigerant R404

Made in Japan

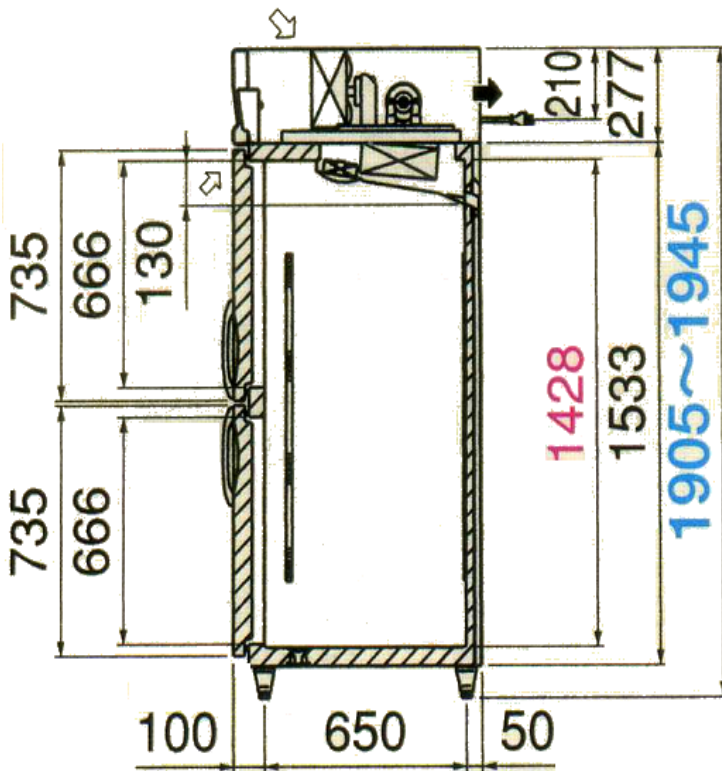

PRODUCT NAME		STAINLESS FREEZER			
DESCRIPTION		573SS			
CABINET	DIMENSIONS		W	D	H
		EXTERNAL	1500	800	1905
	INTERNAL				
EXTERIOR		SUS 430			
INTERIOR		Stainless			
INSULATION		PU			
DOOR		SS Door*4			
REFRIGERATION CYCLE	COMPRESSOR	SANYO, Japan			
	OUTPUT	720W			
	FREON	R404			
	EVAPORATOR	FIN TUBE FORCED CIRCULATION			
	FAN	EVAPORATOR FAN : N2508-200V*32 CONDENSOR FAN : N15108-200V*2			
	POWER	200 - 220V 50/60HZ 3 Phase			
	CONTROLLER	Digital, Electronic			
	CONDENSOR	FIN TUBE FORCED AIR			
COOLING PERFORMANCE	INTERNAL TEMP : -20~-18C INTERNAL RH : 70~80%				
WEIGHT	183kg				
PRICE					
FOB MANILA					

Exclusive Philippine Distributor:

STA. ANA IMPORT EXPORT INC.

3874 Macabulos St., Bangkal, Makati City, Philippines, 1233

Tel Nos. 889-0040, 889-0049, 889-0051, and 843-1322

Fax No. 889-0050

Email: Kinco@eastern.com.ph

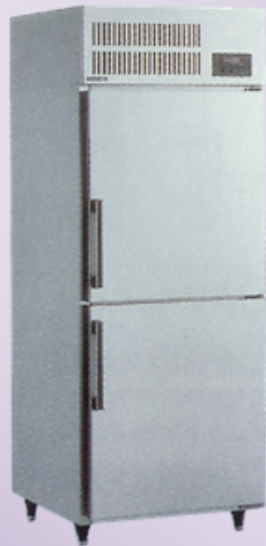

233-FFB Blast Freezer

Features

- 1. Temp at -40 to -20C
 - 2. SANYO, Japan Compressor
 - 3. Environmental Friendly Refrigerant R404A
- Made in Japan

	PRODUCT NAME		STAINLESS BLAST FREEZER			
	DESCRIPTION		233-FFB			
	CABINET	DIMENSIONS		W	D	H
			EXTERNAL	750	800	1905
			INTERNAL			
	EXTERIOR		SUS 430			
	INTERIOR		Stainless			
	INSULATION		PU			
	DOOR		SS Door*2			
	REFRIGERATION CYCLE	COMPRESSOR		SANYO, Japan		
OUTPUT		1100W				
FREON		R404A				
EVAPORATOR		FIN TUBE FORCED CIRCULATION				
FAN		EVAPORATOR FAN : N2508-200V*32 CONDENSOR FAN : N15108-200V*2				
POWER		200-220V 50/60HZ 3 Phase				
CONTROLLER		Digital, Electronic				
CONDENSOR		FIN TUBE FORCED AIR				
COOLING PERFORMANCE		INTERNAL TEMP : -40~-20C INTERNAL RH : 70~80%				
WEIGHT		183kg				
PRICE						
FOB MANILA						

Exclusive Philippine Distributor:

STA. ANA IMPORT EXPORT INC.

3874 Macabulos St., Bangkal, Makati City, Philippines, 1233

Tel Nos. 889-0040, 889-0049, 889-0051, and 843-1322

Fax No. 889-0050

Email: Kinco@eastern.com.ph